

**Operating Instructions
Bedienungsanleitung
Manuel d'instructions
Gebruiksaanwijzing
Bruksanvisning
Manuale di istruzioni
Manual de Instrucciones**

Full-Flap Face High-Power Cassette Player/RDS Receiver
RDS Autoradio-Cassettenkombination; High Power; Flip-Down Bedienteil
Façade inclinable détachable/Haute Puissance/Lecteur de Cassette/Récepteur RDS
High-Power RDS radio/cassettespeler met volledig kantebaar frontpaneel.
Hög uteffekts kassett/RDS radio med flip front
Sinto/lettore a cassette high power con RDS
Caratula total tipo "FLAP" Radio-cassette de alta potencia con RDS

CQ-FX65/FX45LEN

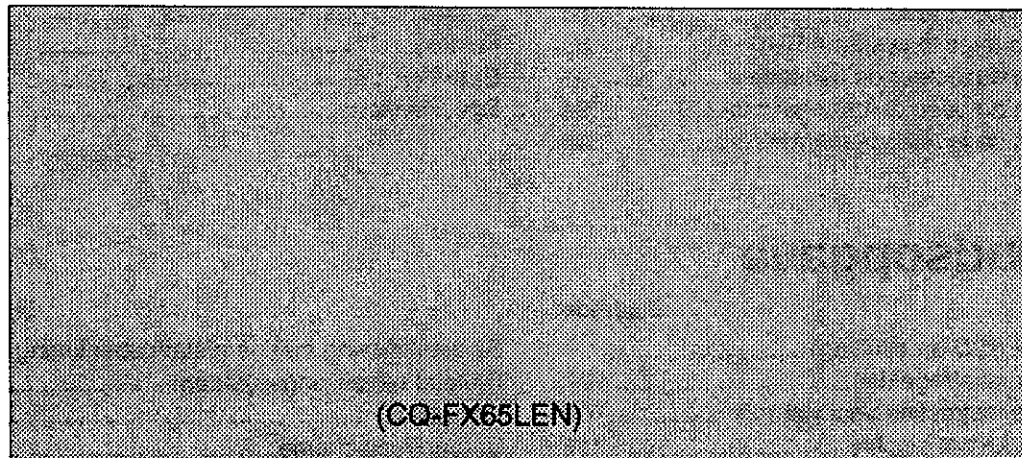

Panasonic

Before operating this set, please read these instructions completely.
Bitte lesen Sie diese Bedienungsanleitung vor der Inbetriebnahme aufmerksam durch.
Nous vous recommandons de lire attentivement ces instructions avant d'utiliser cet appareil.
Lees deze gebruiksaanwijzing in zijn geheel door alvorens dit apparaat in gebruik te nemen.
Läs noga dessa anvisningar före apparatens användning.
Prima di adoperare l'apparecchio, vogliate leggere attentamente le istruzioni.
Antes de poner en marcha el aparato, sírvase leer atentamente estas instrucciones.

Contents

	Page		Page
Precautions (ISO Connector).....	4	Remote Control Basics	32
Precautions	11	Anti-Theft System	34
Power and Sound Controls	12	Installation.....	37
Display Controls.....	15	Electrical Connection	40
Radio Basics	16	Speaker Connections.....	41
RDS (Radio Data System) Reception.....	19	Fuse	42
Cassette Tape Player Basics	27	Maintenance	42
CD Changer Basics	30	Specifications.....	42

Inhaltsverzeichnis

	Seite		Seite
ISO-Anschlußschema-Achtung-sehr wichtig.....	5	Grundlagen für Fernbedienung	64
Vorsichtsmaßnahmen.....	43	Diebstahlschutz	66
Stromversorgung und Klangregler.....	44	Einbau	69
Display-Regler	47	Elektrischer Anschluß.....	72
Rundfunkempfang	48	Anschluß der Lautsprecher	73
Radio-Data-System (RDS)-Empfang.....	51	Sicherung	74
Cassettenwiedergabe.....	59	Pflege	74
Grundlagen für die Bedienung des CD-Wechslers	62	Technische Daten	74

Sommaire

	Page		Page
Précautions (Connecteur ISO)	6	Système anti-vol.....	98
Précautions.....	75	Installation	101
Mise sous tension et commandes de son	76	Connexions électriques	104
Utilisation de la radio	80	Connexion des haut-parleurs	105
Réception avec le système RDS	83	Fusible	106
Utilisation du lecteur de cassette	91	Entretien	106
Utilisation de base du changeur de CD	94	Spécifications	106
Utilisation de la télécommande.....	96		

Inhoudsopgave

	Bladzijde		Bladzijde
Belangrijk (ISO aansluiting).....	7	Basisbediening met de afstandsbediening	128
Voorzorgsmaatregelen	107	Diefstal beveiligingssysteem	130
Algemene instructies voor gebruik	108	Inbouwen	133
Regelen van het display.....	111	Bedradingsschema.....	136
Basisbediening van de radio.....	112	Aansluiten van de luidsprekers.....	137
RDS (Radio Data Systeem) ontvangst	115	Zekering.....	138
Basisbediening van de cassettespeler	123	Onderhoud.....	138
Basisbediening van de CD-wisselaar	126	Technische gegevens	138

Panasonic welcomes you to their constantly growing family of electronic products owners. We endeavor to give you the advantages of precise electronic and mechanical engineering, manufactured with carefully selected components, and assembled by people who are proud of the reputation their work has built for our company. We know this product will bring you many hours of enjoyment, and after you discover the quality, value, and reliability we have built into it, you too will be proud to be a member of our family.

Precautions

Volume Level

For your driving safety, keep the volume level low enough to be aware of road and traffic conditions.

Car Washing

To avoid electrical shorts which may cause fire, or other damage, do not expose this equipment (including the speakers and tape) to water or excessive moisture.

Car Ventilation

If your car is parked for several hours in direct sunlight, the temperature inside the car may become very high. It is advisable to drive the car and give the interior a chance to cool down before switching the unit on.

Power Supply

This equipment is designed to be used in a car having 12-Volt negative ground battery system.

Tape Mechanism

Keep magnets, screwdrivers and other metallic objects away from the tape mechanism and tape head.

Service

This unit is made of precision parts. Do not attempt to disassemble or adjust any parts. For repair, please consult your nearest authorized Panasonic Service Center.

About Preset Memory

The preset memory is cleared to return to the original factory setting when the power connector or battery is disconnected.

Note:

This operating instruction manual is for two models CQ-FX65LEN and CQ-FX45LEN. The differences between these models' are mentioned below. All illustrations throughout this manual represent model CQ-FX65LEN unless otherwise specified.

MODEL \ Operating Controls	SPECTRUM ANALYZER	LCD Color
CQ-FX65LEN	Yes	Multi
CQ-FX45LEN	None	Blue

Power and Sound Controls

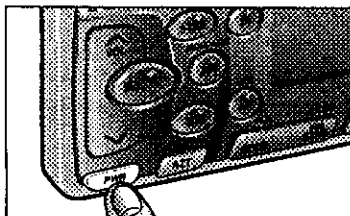
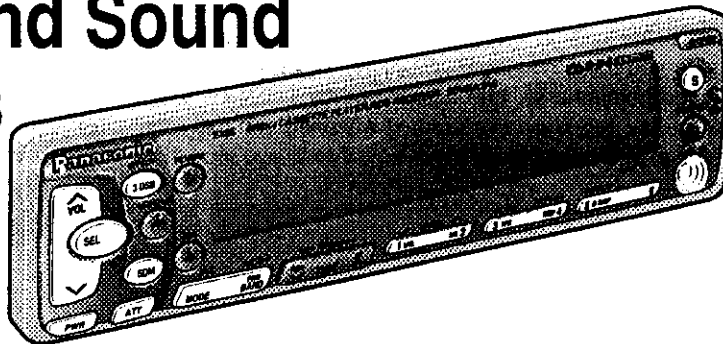

Power

If the car is not already running, turn the key in the ignition until the accessory indicator lights.

Press PWR to switch on the power.

Press and hold PWR again to switch off the power.

Note: When power is switched on for the first time, demonstration display appears. To release this display, press and hold PWR and switch power off.

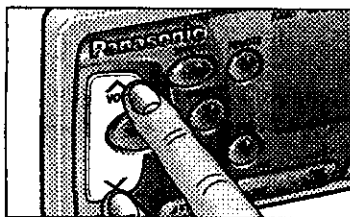

Volume

Press "VOL+" or "VOL-" to increase or decrease volume.



Volume Level

0 to 40

Press "VOL+" or "VOL-" for more than a half second to sequentially change numeric levels on the display.

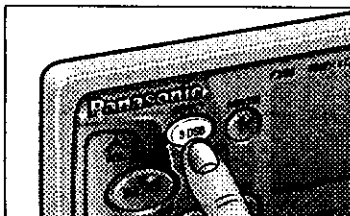

3•DSB (3-Dimensional Surround and Super Bass) and Loud Switching

① Press 3•DSB to switch on or off 3•DSB and Loud as follows.

3 DBS OFF	3 DBS ON	3 DBS OFF
LOUD OFF	→ LOUD OFF	→ LOUD ON

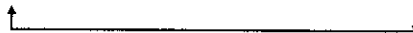

② Press and hold 3•DSB for more than 2 seconds when 3•DSB is ON, a degree of effect can be selected.

Press ^ VOLV to select one of the 10 degrees (0 through 9).

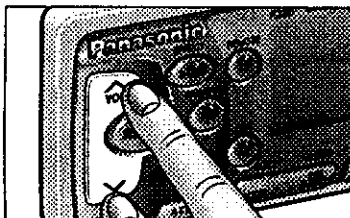

3•DSB System

It is a new sound system combining 3-dimensional sound from two front speakers with rear channel super bass.

The 3•DSB employs Spacializer® ICs of Desper Products, Inc.

- When 3•DSB is turned on while receiving an AM monaural broadcast or when you are listening to an FM broadcast in monaural mode, you will be able to listen to it with a virtual stereo effect from 4ch speakers.

Note: This unit is equipped with anti-volume-blast circuit which serves as an automatic volume level adjuster so that you will not be deafened with sudden loud volume.

This system operates as below. When PWR is first pressed to switch on, the volume level is low. After that, the volume level gradually returns to the level when the switch is turned off.

Anti-volume-blast circuit is not effective when volume level is lower than position 20 at the display.

Power and Sound Controls continued

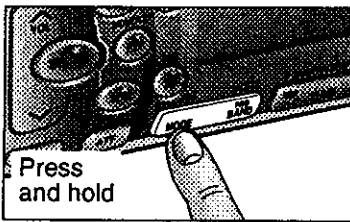

Press and hold

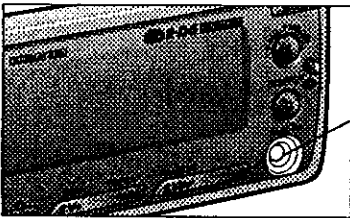

Selecting Auxiliary Source

- ① Press and hold MODE (AUX) for more than 2 seconds to select AUX Input mode.



- ② Connect the auxiliary equipment (any other appropriate equipment) to the AUX Jack.

AUX Jack

Canceling AUX Input mode

Press MODE (AUX) to resume the previous mode.

Sound Memory

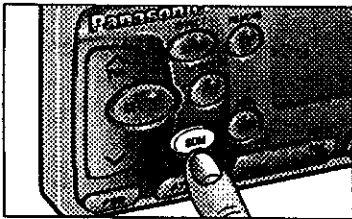

Sound Design Memory Mode Selection

A desired sound setting (except for VOL and ATT) can be memorized and recalled.

Press SDM to select the sound design memory mode.

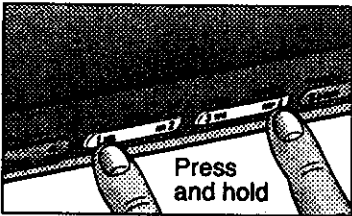

Press and hold

Sound Design Memory Input

- To preset a desired sound setting, press the corresponding preset memory button (1 to 4) for more than 2 seconds in sound design memory mode.



- The preset memory buttons 5 and 6 are not valid for memory write.

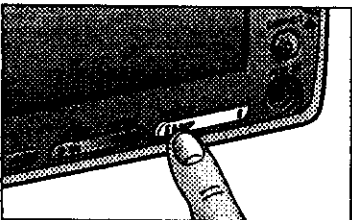

Sound Design Memory Call

- When a desired preset memory button is pressed in sound design memory mode, the corresponding sound setting is called out.



The called preset number is displayed.

- The preset memory button 5 is recommended for setting.
- The preset memory button 6 is used to release all sound settings.

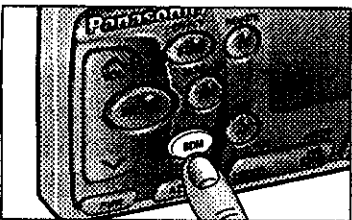

To change to normal mode

Press MODE or SDM to change to the normal mode.

Note: When the sound design memory mode is selected but no operation is made within 5 seconds, the mode will return to the normal mode.

Display Controls

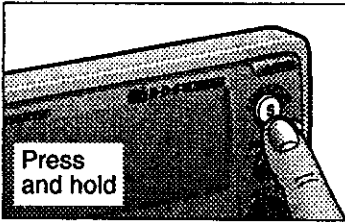

Dimmer Switching

Press and hold S (S·ANALYZER/DIM) for more than 2 seconds (FX45LEN: Press  (DIMMER)) to change the brightness of the LCD from one level to another in a cycle of 3 levels as follows:

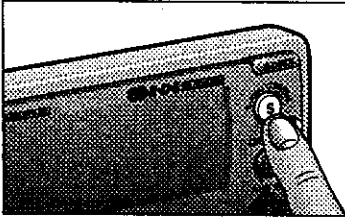
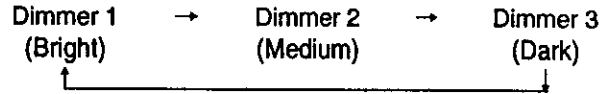

Spectrum Analyzer Display Switching (Only for CQ-FX65LEN)

Press S (S · ANALYZER/DIM) to change the spectrum analyzer display from one spectrum analyzer to another in a cycle of 6 kinds plus demonstration mode.

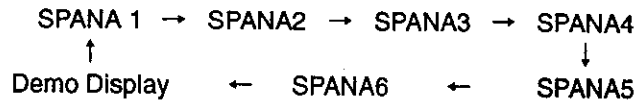

<p>Spectrum analyzer 1</p>	<p>Spectrum analyzer 2</p>
<p>Spectrum analyzer 3</p>	<p>Spectrum analyzer 4</p>
<p>Spectrum analyzer 5</p>	<p>Spectrum analyzer 6</p>

Radio Basics

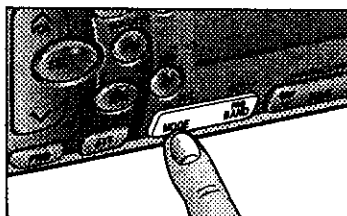
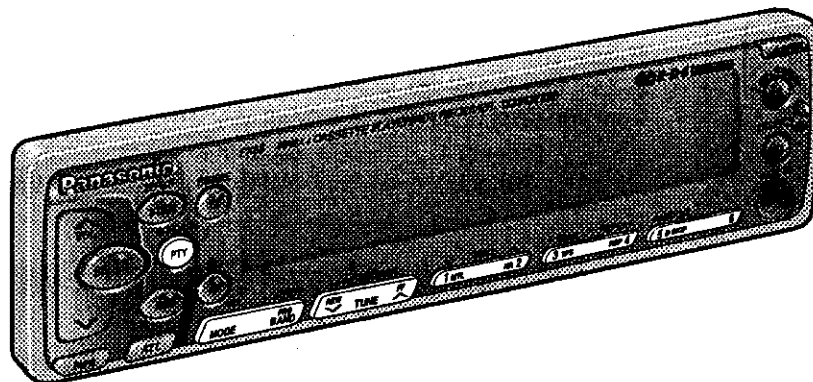

To change Tuner Mode

Press MODE to switch the operation mode in the following order.

Tuner → Tape → CD Changer Control
 ↑ AUX ↓

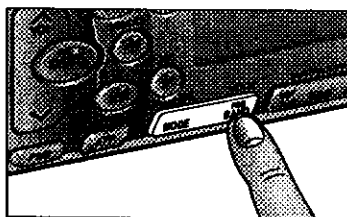

Selecting a Band

Press BAND to select the bands in the following order.
 "ST" indicator lights if the station is broadcasting in stereo.

FM1 → FM2 → FM3 → AM(LW/MW)
 ↑ ↓

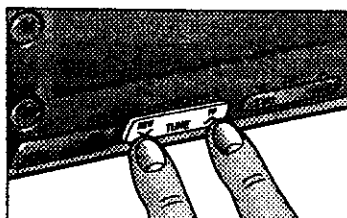

Manual Tuning

Press "VTUNE" or "TUNEΔ" to move to a higher or lower frequency.



Press and hold "VTUNE" or "TUNEΔ" to move to a lower or higher frequency rapidly.

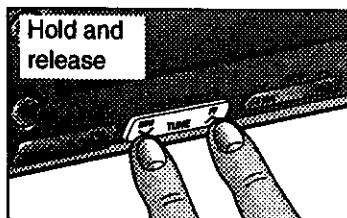

Hold and release

Seek Tuning

Press and hold "VTUNE" or "TUNEΔ" for more than a half second, then release. The radio automatically stops on the next station.

Preset Station Setting

Up to 24 stations can be preset in the station memory as follows;

FM1	FM2	FM3	AM(LW/MW)
6 stations	6 stations	6 stations	6 stations

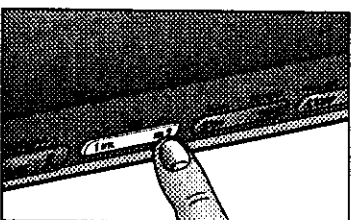
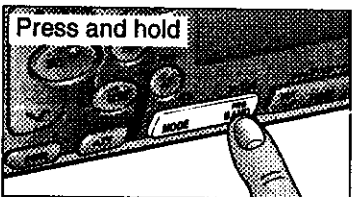
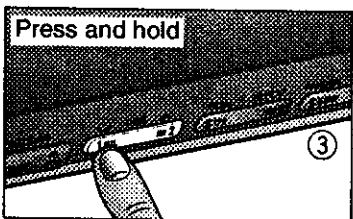
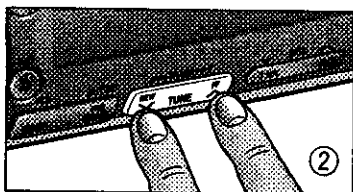
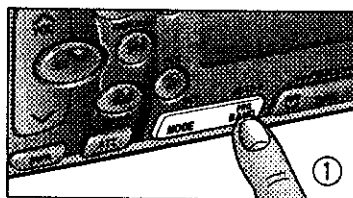

Manual Station Preset

- ① Press BAND to select a desired band.
- ② Use manual or seek tuning to find a station that you want to program into memory.
- ③ Press and hold one of the station selector buttons 1 through 6 for more than 2 seconds until the display blinks. Repeat the process to set other stations for the FM1 to AM bands.



— Preset Channel Indicator

Note: You can change the memory setting by repeating the above procedure.

Tuning in a Preset Station

Press any of the buttons 1 through 6 to tune in the station preset by the above steps ① to ③.

Auto Station Preset

Select a band, press and hold BAND (AUTO · P) for more than 2 seconds.

- The six strongest available stations will be automatically set in memory on preset buttons 1 through 6.
- Once set, the preset stations are sequentially scanned for 5 seconds each.
- Press the appropriate preset button for the station you want to hear.

CAUTION: For safety reasons, do not attempt to program while driving.

RDS (Radio Data System) Reception

Many FM stations are broadcasting added data compatible with RDS. This radio set offers convenient functions using such data.

AF (Alternative Frequency)

When receiving condition becomes poor, an RDS station with the same program will be automatically selected.

EON (Enhanced Other Networks)

When EON data is received, the EON indicator lights and the TA and AF functions are expanded.

TA: Traffic information from not only the station now tuned in to but also other stations of the same network can be received.

AF: The frequency list of the RDS stations preset by received EON data is updated.

TA (Traffic Announcement)

When an FM station that periodically provides the latest traffic information is received, the TP indicator lights. If TA ON is set, FM traffic information automatically interrupts your listening to a tape, CD changer, or AUX source until it ends, then you will listen again to whatever you have been listening to.

REG (Region)

The AF, Best Station Research, PI Seek functions will be as follows:

REG ON : The frequency changes only with the same regional program. This function is mainly used while driving in the same area, for example, in a city.

REG OFF: The frequency changes even with a different regional program if the station is in the same network. The broadcast may be different depending on the case. This function is mainly used when driving far from one region to another.

WHAT PROVIDES EON CAPABILITIES

EON lets the radio set take advantage of RDS information much more than before. It constantly updates the AF list of all presets, including the station currently tuned in to. So, even if you change preset far from home, you will be able to receive the same station at an alternative frequency, or another station serving the same program if any. EON also keeps track of locally available TP stations for quick reception.

Note: When you're in "AF ON" mode, auto preset memory only works for RDS station. When in "TA on" mode, it only works for TP stations. To make auto preset for ordinary stations, cancel AF mode and switch to TA off in advance.

PS (Program Service Name)

When an RDS station is received, the RDS indicator lights and automatically displays the name of that station instead of the frequency. When D (DISP) is pressed during PS display, the frequency is displayed for 3 seconds, then PS display returns.

PI (Program Identification)

If a preset RDS station is poor in receiving condition when it is selected, the automatic seek (PI Seek) starts to seek the same program and tune in to it.

PTY (Program TYPe)

Program type identification signal

Example : News, rock, classical music

RDS (Radio Data System) Reception continued

A. Basic Operation in RDS Reception (PS, AF, CT, PI)

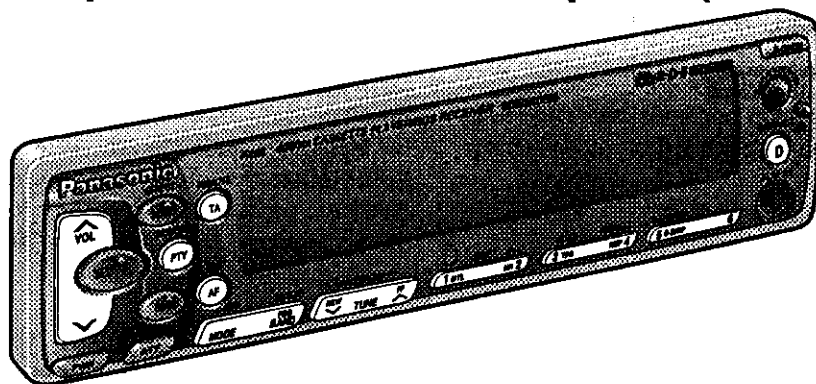

RDS Reception

RDS can be used on the FM1, FM2 or FM3 band only. When an RDS station is received for the first time, the AF network can be used and RDS operation can be performed at the same time because RDS is already set to AF1 (AF ON) on this set. Best Station Research is also activated simultaneously.



- Select AF ON if you wish to use the AF network of an RDS station. Best station research is activated at the same time.
- Select AF OFF if the AF network of an RDS station is not necessary.

Best Station Research

If a preset RDS station is in poor condition of reception when you try to tune in to it, the best frequency is selected from the AF list of that station.

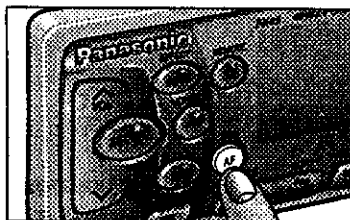

To Change AF Mode

Press AF to change AF ON and activate Best Station Research at the same time. (3 seconds maximum)

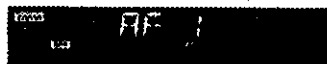

Notes:

1. Default mode is AF1.
2. AF1 has a low level of AF operating sensitivity in urban areas. Therefore, AF does not frequently operate even if sensitivity is temporarily lowered between skyscrapers, for examples.
3. AF2 is for suburban areas with a higher level of sensitivity than AF1.

For Seek Tuning, RDS Station Preset, Tuning in a RDS preset station, and Auto RDS Station Preset, please refer to Radio Basics (page 16 to page 18).

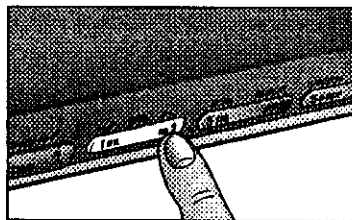

RDS seek tuning (PI seek)

The PI seek function may be used if an RDS station selected from the memory is poor in receiving condition. Press the preset button again for the station now tuned in to.



PI Seek: If Best Station Research fails in selecting the best station, the PI seek function operates to automatically tune in to the same program.

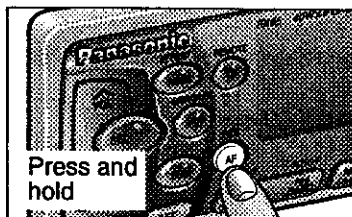

Region (REG) Switching

Press and hold AF(REG) for more than 2 seconds in AF mode to alternately select REG ON and REG OFF.



Note:

If you wish to stay with the same program, keep REG ON. If you keep REG OFF, there is a higher possibility of returning in to an AF station in better receiving condition.

The relationship of the PI seek function with REG ON and REG OFF is as described above.

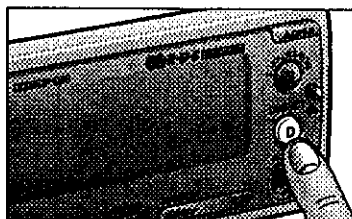

Changing Display

- Press D(DISP) to change the display.
(Frequency display continues for only 3 seconds, returning to PS display after that.)

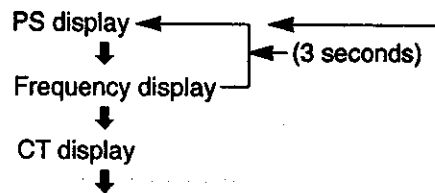

Clock Time (CT) System

The CT (24-hour) system may not properly operate in areas where RDS CT service is not available. Once CT service is received, the CT system keeps operating. "NO CT" is displayed in areas where no CT service is available.



Clock Display

Press D (DISP) to indicate the clock display.

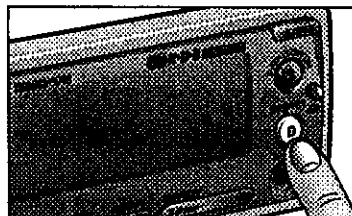

RDS (Radio Data System) Reception continued

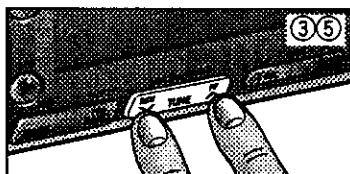

Initial Time Setting

Press BAND to change to AM mode.

- ① Press D(DISP) "AM NO CT" is displayed.
- ② Press and hold D(DISP) again for more than 2 seconds "hours" blinks indicating the time setting mode is activated.
- ③ To set hours, press "TUNE ^ or VTUNE".
- ④ Press D(DISP) again for minutes setting.
- ⑤ To set minutes, press TUNE ^ or VTUNE. Hold "^" or "V" change numbers rapidly.
- ⑥ When set the time, press D(DISP).

Notes:

- If CT display is kept on, it remains on even if PWR and ACC are tuned off and back on again.
- In other mode, press D (DISP) to get RDS CT-service.

B. TP Reception

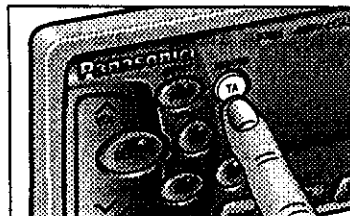
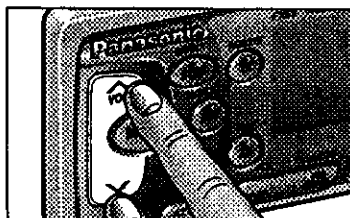
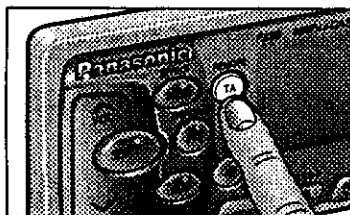

Select traffic information (TA on) mode

Press TA to switch ON and keep it there when you wish to listen to traffic information. Press TA to switch OFF when no traffic information is needed.



Volume Setting (Only for TA on mode)

Adjust the volume as desired using "VOL ^" or "V VOL" while receiving traffic announcement. (TA)

After volume for traffic announcement (TA) is set, the difference between normal volume and TA volume is automatically stored in the memory (up to 5 levels) so that next traffic information will be received at the preceding TA volume which may be higher or lower than normal volume.

Normal volume can be changed up to 5 levels upward or downward.

If an adjusted level of volume is over 40 or less than 0, any further change will not be made.

When receiving a station other than TP station (including EON stations)

A traffic information station is automatically searched for and the radio automatically stops the next available TP station. EON Capabilities:

EON lets the radio take advantage of much more RDS information than before. It constantly updates the AF lists for all switch presets far from home, you will receive an alternative frequency for the same station, or another station carrying the same program, when such exists. EON also keeps track of locally available TP station.



→
Press TA.



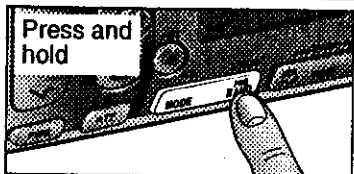
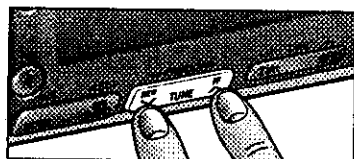

TP Seek Tuning

Press "∇TUNE" or "TUNE∧" for more than a half second, then release. The radio automatically stops on the next available TP station.

Auto TP Station Preset

Press and hold BAND (AUTO-P) for more than 2 seconds. The six strongest available TP stations are automatically set in memory on the preset button 1 through 6.

Once set, the preset stations are sequentially scanned for 5 seconds each.

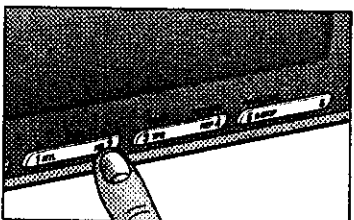

Tuning in a TP station preset

Press any of the preset buttons 1 through 6 that you want to hear. And then Best Station Research function is activated to automatically select the strongest available frequency for the TP station (through the built-in frequency) lists, if reception is weak.

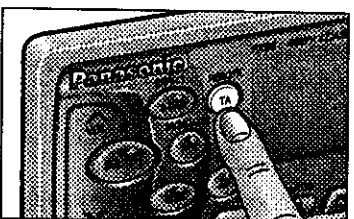

Muting TA on

Press and hold TA for more than 2 seconds to light "TA on". Then Traffic Announcement (TA) function is activated to operate, allowing you to listen to only Traffic Program whenever it is available.

Muting TA on canceling (Muting TA on → TA on)

Press TA again.

Press "VOL∧" to increase the volume level.

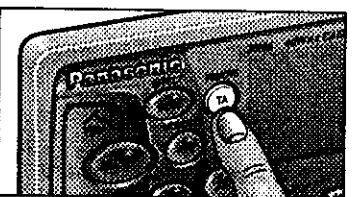

TP Auto Search

If receiving conditions are poor when TA is on during muting and if there is no other alternative frequency in the same network, a traffic announcement station in good receiving condition is automatically searched for.

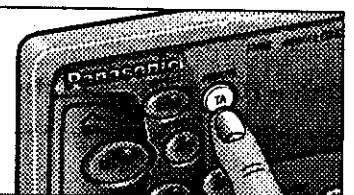

Tape/CD · C/AUX TA on

Press TA during tape, CD changer, AUX mode.

TA on mode is selected. while listening to the source in that mode, wait for Traffic Announcement to being.

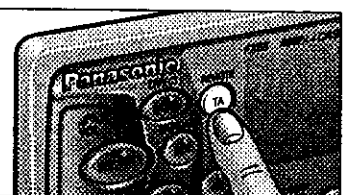
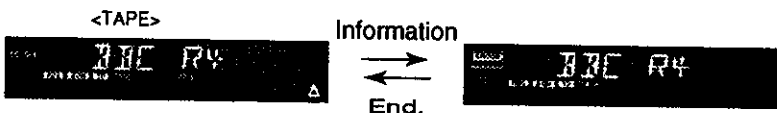

Switching to TA off Mode

Select either one of the following steps.

- Press TA when TA is ON.
- Press and hold TA for more than 2 seconds when Muting TA is ON.
- Press TA when tape/CD/C/AUX TA is ON.

RDS (Radio Data System) Reception continued

C. PTY Reception

(There are some areas where PTY service may not be available.)

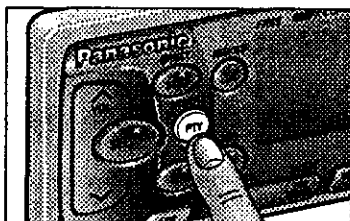

Switching to PTY mode

Press PTY to select PTY display mode, and the PTY of the broadcast now received is displayed.



"NO PTY" is show if there is no corresponding program type.

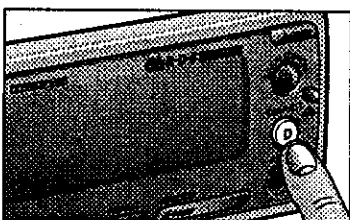

Changing PTY Display Language

Pressing D(DISP) each time in PTY mode to alternate the language between English and Swedish.

Press D (DISP).

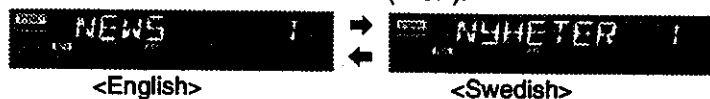

<English>

<Swedish>

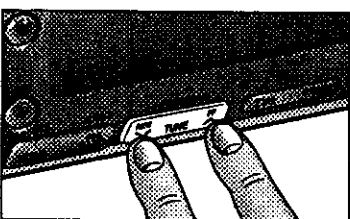

Program Type Selection

Press "∨ TUNE" or "TUNE ∧" to select the program type in sequence as follows.

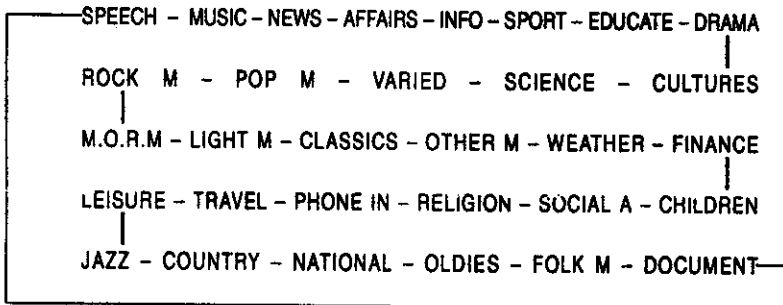

When the desired selection has been made, press BAND. Then automatic seek will start to tune into the station broadcasting the selected program type.

Note :

Seek tuning does not operate as long as "NO PTY" is displayed.

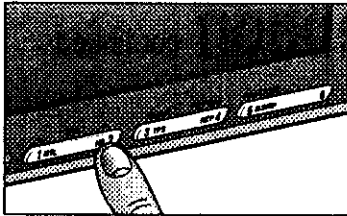
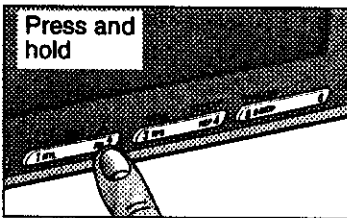

TABLE of PTY CODE and program Type

Press any of the preset button 1 through 6 that you want to desire the program type. Those buttons are already stored program types as below. (Initial setting)

<PRESET PTY>

Preset NO.	1	2	3	4	5	6
Program Type	NEWS	SPEECH	SPORTS	POP. MUSIC	CLASSICS	MUSIC
Display	NEWS 1	SPEECH 2	SPORT 3	POP M 4	CLASSICS 5	MUSIC 6
	NEWS	AFFAIRS INFO EDUCATE DRAMA CULTURES SCIENCE VARIED WEATHER FINANCE CHILDREN SOCIAL A RELIGION PHONE IN TRAVEL LEISURE DOCUMENT	SPORT	POP M	CLASSICS	ROCK M M.O.R.M LIGHT M OTHER M JAZZ COUNTRY NATIONAL OLDIES FOLK M



Program Type Preset

Press and hold one of the buttons 1 through 6 for more than 2 seconds to preset the desired program type selection in that button.

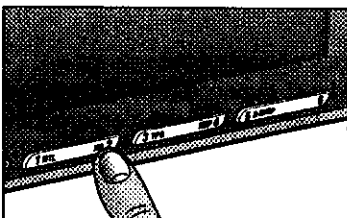

Tuning in a PTY Preset Station

Press any of the preset buttons 1 through 6 that you want to hear.

RDS (Radio Data System) Reception continued

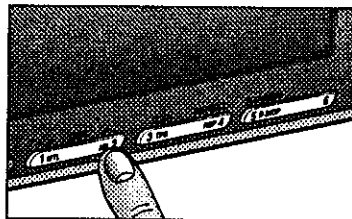

Searching for PTY

- ① Select the desired station from among those preset in the preset number buttons 1 through 6. Then, the preset PTY and that preset number are displayed for 5 seconds.



- ② While the desired type from 6 presets is displayed, take either of the following two steps.

- A) Press the same preset button again.
- B) Press BAND.

If the desired PTY station is available, it is directly received. If it is not, "NO PTY" blinks and the radio returns to the station that was received before the search.

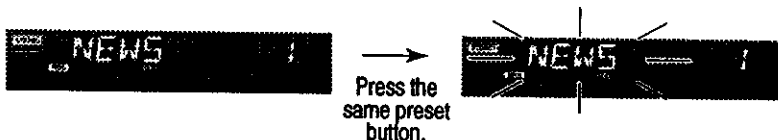

Press the same button again to cancel.

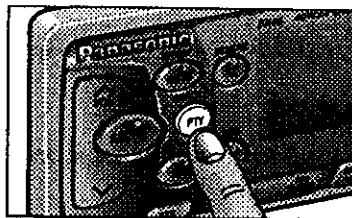

Canceling of PTY Mode

Press PTY to cancel.

The set returns to the state existing before PTY mode while the receiving frequency remains unchanged.

Emergency Announcement Reception

(Some areas are not covered by emergency announcement service.)

If an emergency announcement is broadcast during tape/CD changer/AUX mode, the radio is automatically selected to receive the emergency announcement. "ALARM" blinks.

Cassette Tape Player Basics

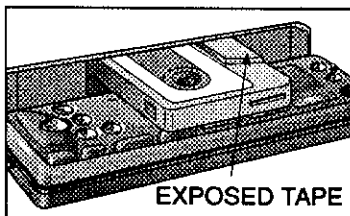
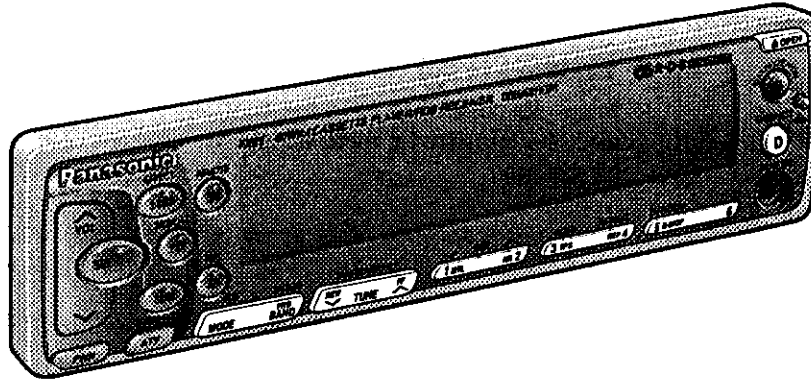

Loading a Cassette

- ① Press ▲ (OPEN) to open the front panel.
- ② Insert the cassette with the exposed tape side facing to the right.
- ③ Close the front panel by hand.

Note:

- If the front panel is open with power OFF, the PWR button only is valid.
- If the front panel is open with power ON, cassette insertion and ▲ (OPEN) button only are valid.

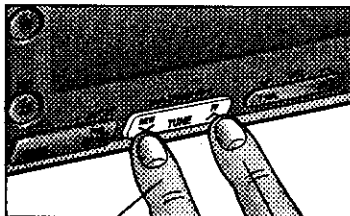

REWIND FAST FORWARD

Rewind and Fast Forward

Press either REW to rewind or FF to fast forward the tape.



- If you rewind the tape fully, it will play same program side again.
- If you fast forward to the end, play will resume from the beginning of the other side of the tape.

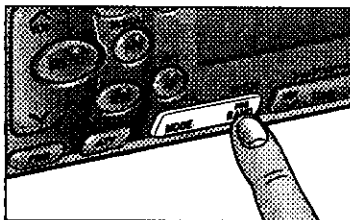

To stop rewind or fast forward, press PRG .

Changing Sides

Press PRG to switch to the program on the other side of the tape.

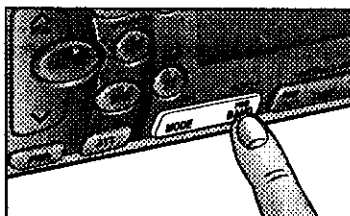

TOP SIDE PLAYING



BOTTOM SIDE PLAYING

Cassette Tape Player Basics continued

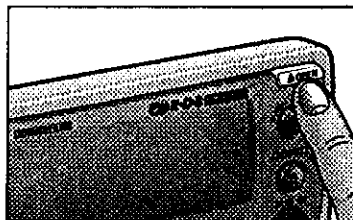

Ejecting the Tape

Press **▲** (OPEN) to open the front panel. Press **▲** (OPEN) again to eject the cassette for removal, and the previous mode of operation will be resumed.

Notes:

- If power is switched off before **▲** (OPEN) is pressed, the cassette will not eject. Switch on the power again and press **▲** (OPEN) twice to eject the cassette.
- The cassette tape should always be removed from the cassette slot when not in use.

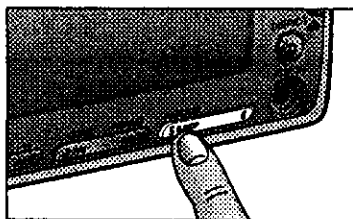

Blank Skip

- Press **5** (B · SKIP) to skip long unrecorded portions on the tape.



- Press **5** (B · SKIP) again to cancel.

Notes:

- "B · SKIP" indicator lights. However, the blank skip operation will not work if REPEAT is on. The repeat function has priority over that of the blank skip function.
- Also the blank skip operation will not work when the unrecorded portions of the tape is less than 15 seconds.

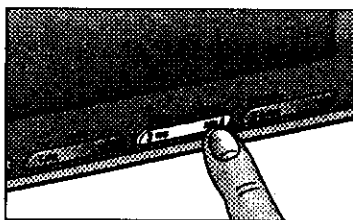

Repeat Play

- Press **4** (REP) to repeat the same music you are now listening to.



- Press **4** (REP) again to cancel.

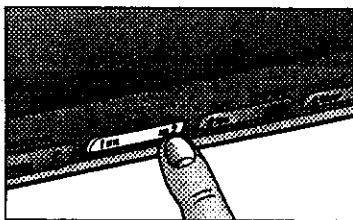

Dolby Noise Reduction

- Press **2** (NR) to set the Dolby B NR mode.



- Press **2** (NR) again to cancel.
- Set the Dolby B NR mode when playing back a tape recorded with Dolby B Noise Reduction.

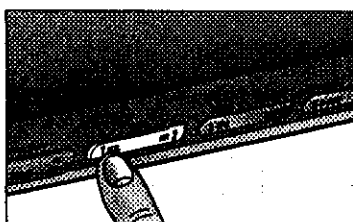

Metal Tape Mode

- Press **1** (MTL) when playing metal or chromium dioxide (CrO₂) tapes.



- Press **1** (MTL) again to cancel.

Note: Playing non-metal tapes in MTL mode causes high frequency imbalance, which affects tone quality.

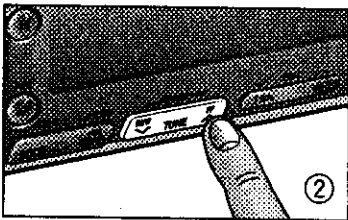
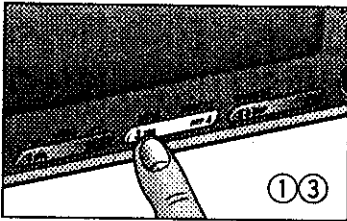

or

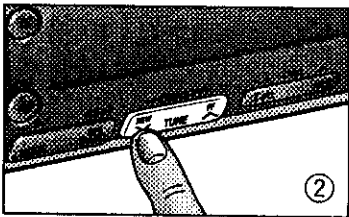

TPS Operation (Tape Program Search)

- ① Press 3(TPS) to activate the tape program search mode

TPS PLAY

- ② From the current selection, decide which program you want to select. Now, press "FF(TUNE^)" several times forward (up to 9 programs) or press "REW(VTUNE)" several times backward (up to 8) to select the corresponding program number.

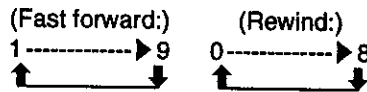

- EX1. To select the current program again press 3 (TPS), and press "VTUNE" once.

TPS REW 0 ▾

- EX2. To select the 1st program backward of the current selection, press 3 (TPS) once, and press "VTUNE" two times.

TPS REW 1 ▾

- EX3. To select the next program, press 3 (TPS) and press "TUNE^" once.

TPS FF 3 ▲

- EX4. To select the 3rd program forward of the current selection, press 3 (TPS) once, and press "TUNE^" three times.

- ③ Press 3 (TPS) again to cancel.

Note:

The TPS mode may not work correctly in the following cases. This, however, does not mean that the unit is defective.

- There is an interval less than 4 seconds or having a high level of noise or hum between programs.
- There is particularly low-level passage during the program.

Note: To maintain your cassette player in top condition, avoid using tapes that are longer than 90 minutes (C-90).

CD Changer Basics

Note:
CD changer functions are applicable to units with optional CD changer unit (sold separately.)

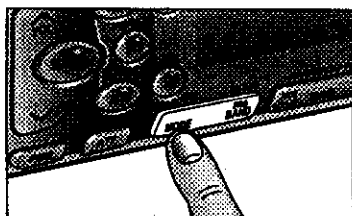
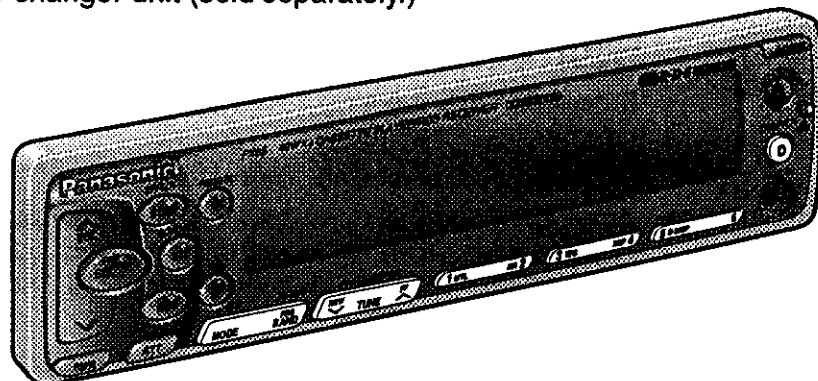

To start the CD Changer

While CD changer is connected, press MODE to change into the CD changer mode and playback starts automatically.

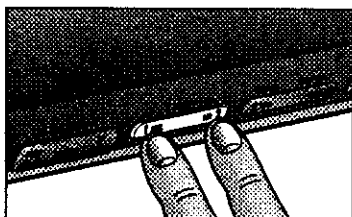
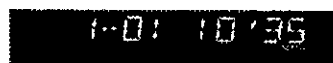

Selecting a Disc

Press "∨DISC" or "DISC∧" to select discs in descending or ascending order.



Then, the selected disc will start to play from the first track.

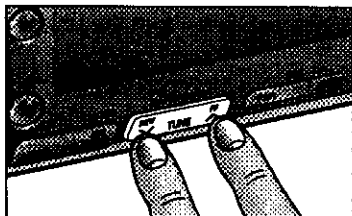

Selecting a Track

- Press "TRACK ►►" once to go to the next track.
- Press "◄◄ TRACK" once to play from the beginning of the current track. Press twice to play the previous track.
- Press repeatedly to skip the desired number of tracks.

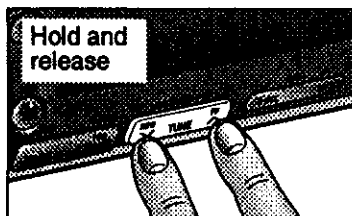

Searching a Track

- Press and hold "TRACK ►►" or "◄◄ TRACK" for more than a half second to activate fast forward or reverse through a track.
- Release "TRACK ►►" or "◄◄ TRACK" to resume the normal CD play.

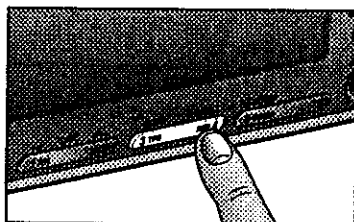

Repeating a Track

- Press 4 (REPEAT) to repeat the current selection.



- Press 4 (REPEAT) again to cancel

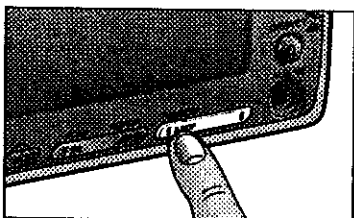

Random Selection

- Press 5 (RANDOM). A random selection of music is played from all available tracks.



- Press 5 (RANDOM) again to cancel.

Note:

The "∨ DISC" or "DISC ∧" is operated, has priority over that of Random play mode. The Random mode will stop and the disc select function will operate once the "∨ DISC" or "DISC ∧" is pressed.

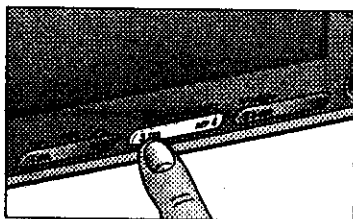

Scanning Tracks

- Press 3 (SCAN). The display blinks and the first 10 seconds of each track on the discs play in sequence.
- Press 3 (SCAN) again to cancel.

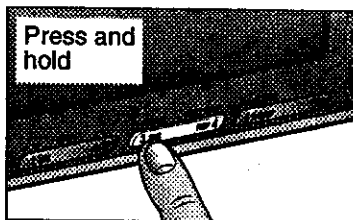

Scanning Discs

- Press and hold 3 (SCAN) for more than 2 seconds. The 1st track of all the discs in the magazine is played for 10 seconds each.
- Press and hold 3 (SCAN) again for more than 2 seconds to cancel.

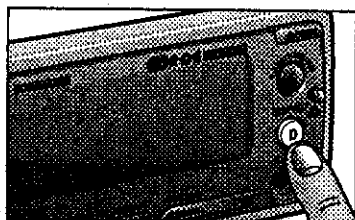

Changing the Display

Press D (DISP) to switch the display in sequence as follows.

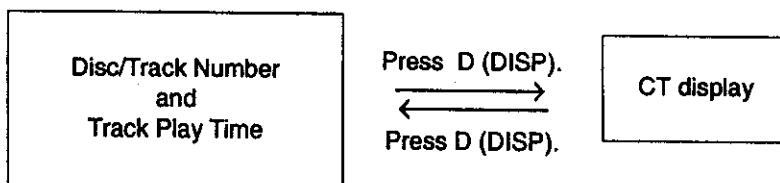

CD Changer Basics continued

Error Display Messages

	<p>Displays when the compact disc is dirty or upside down. Selects the next available compact disc.</p>
	<p>Displays when compact disc is scratched. Selects next available compact disc.</p>
	<p>Displays when the unit stops operating for some reason. Press RESET on the CD Changer (optional).</p>
	<p>Displays when there is no disc in the magazine.</p>

Remote Control Basics

Battery Replacement:

1. Remove the battery holder.
Pull the holder by the Position B while pushing Position A in the direction indicated by the arrow.

2. Replace the battery.
Set a new battery properly with (+)side up as illustrated.

3. Insert the battery holder.
Push in the holder to the original position.

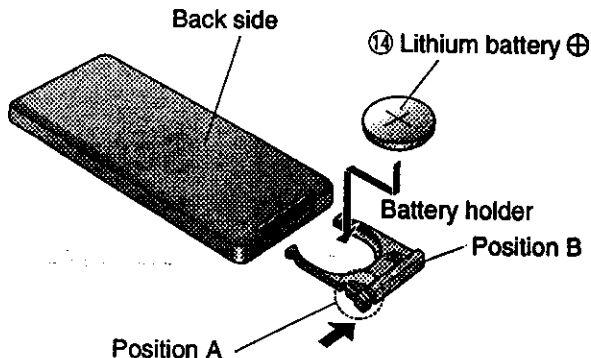

Note on Batteries:

Old batteries must immediately be removed and disposed.

Battery Information:

- Designated Battery: Panasonic Lithium Battery (CR2025)
- Battery Life: 6 months with normal use (in normal room temperature)

Caution:

Improper use of batteries may cause overheating, explosion or ignition, resulting in injury or fire. Battery leakage may cause damage to the unit.

- Do not disassemble or short the batteries. Do not throw the batteries into the fire.
- To avoid the risk of accident, keep the batteries out of reach of children.

Remote Control Basics continued

Names of Main Controls: _____ <Only for CQ- FX65LEN>

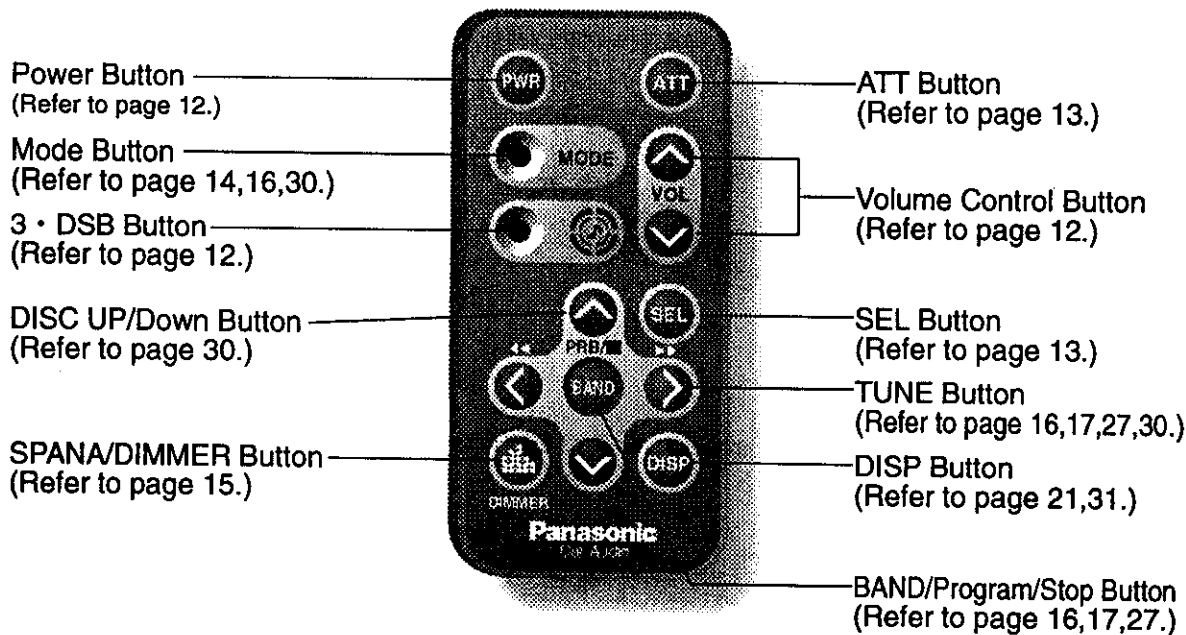

Names of Main Controls: _____ <Only for CQ- FX45LEN>

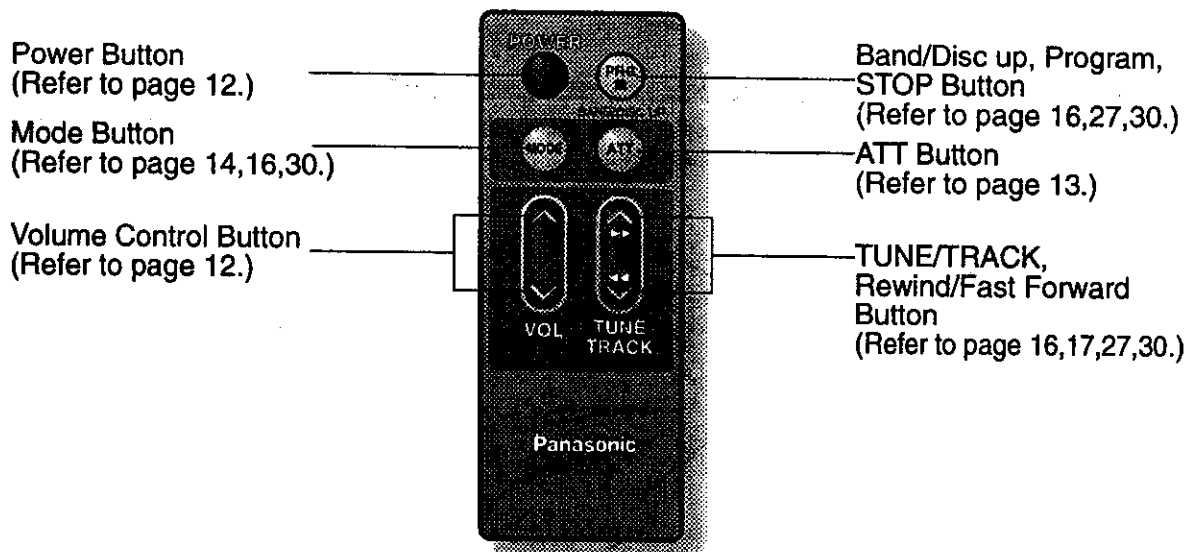

Anti-Theft System

This unit is equipped with a removable face plate. By removing this face plate, the radio becomes totally inoperable. The security indicator will blink.

To Remove the Removable Face Plate

- ① Switch off the power.
- ② Press the release button (). The removable face plate will be released.

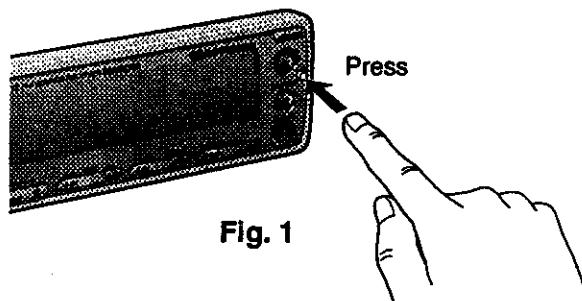

- ③ Remove the removable face plate by pulling on the right side of the unit. Place the removable face plate in a supplied case.

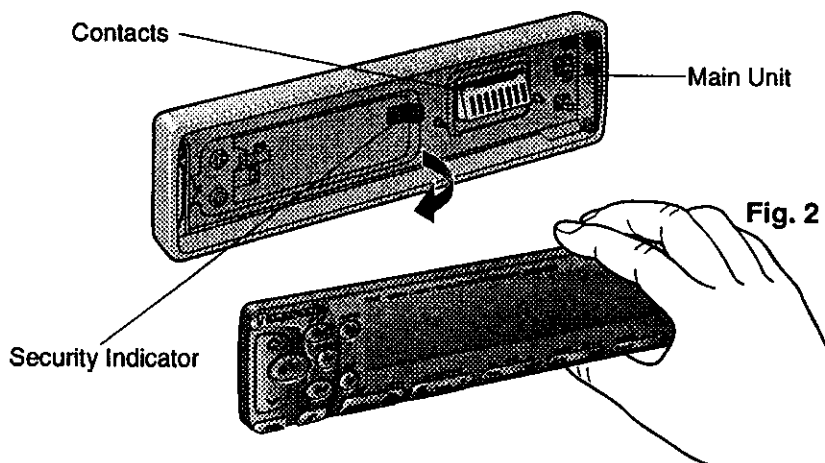

- ④ As shown in Fig.3, gently push the lower side of the case and open its cover. Keep the removable face plate in the case. Then, you can bring the plate safely.

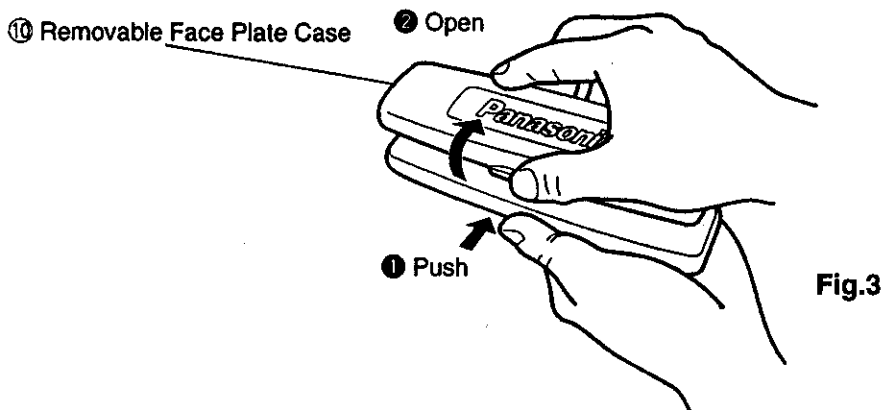

To install the Removable Face Plate

① Slide the left side of the removable face plate in place.

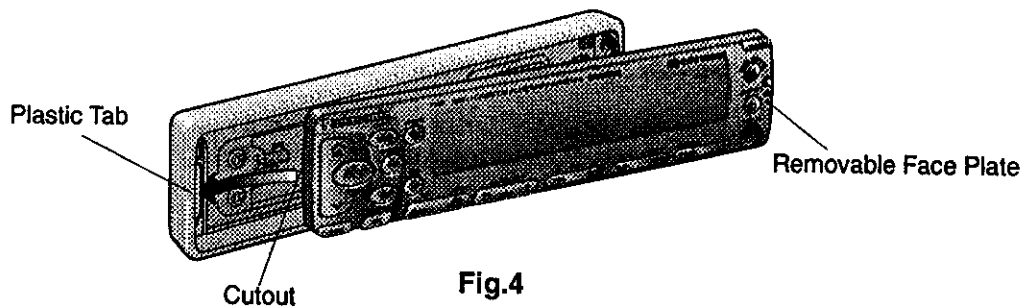

Fig.4

② Press the right end of removable face plate until "click" is heard.

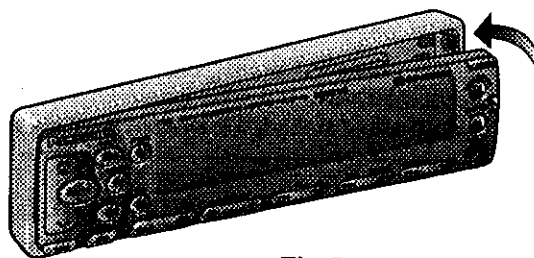

Fig.5

Caution:

1. Before removing the removable face plate, make sure the power is off.
2. This removable face plate is not water-proof. Do not expose it to water or excessive moisture.
3. Do not remove the removable face plate while driving your car.
4. Do not place the removable face plate on the dashboard or nearby areas where the temperature rises to high levels.
5. Do not touch the contacts on the removable face plate or on the main unit, since this may result in poor electrical contacts.
6. If dirt or other foreign substances get on the contacts, wipe them with a clean, dry cloth.

Anti-Theft System continued

Warning Alarm/Horn Alert

Caution

This car radio is equipped with an integrated Warning Alarm & Horn Alert in order to make robbery more difficult.

But it has to be secured that the installation will be properly done so that the Warning Alarm & Horn Alert may work in a perfect way. Concerning the installation the following points have to be observed:

1. The supplied mounting collar has to be firmly fixed with the mounting tabs to the dashboard.
2. The radio has to be put into the mounting collar in that way that it exactly ends with the collar.
3. Please make sure that the technical features (impedance and power) of the speakers installed correspond to the specifications of this car radio (see technical specifications).

Only when these three points are observed during the installation, the correct function of the "Warning Alarm"/"Horn Alert" will be secured.

If the main unit is not correctly wired and installed, the system may accidentally sound the alarm.

Warning Alarm, Horn Alert and Security Indicator



The security indicator blinks when the removable face plate is removed from the unit. Furthermore, the alarm will set off for 1 minute then reset when an attempt is made to remove the unit from the mounting collar.

Activate Warning Alarm, Horn Alert and Security Indicator

1. Press and hold SEL for more than 4 seconds when the power is ON. "ALARM ON" is displayed, and the security indicator and Warning Alarm turn ON.

Note: The ALARM mode is inactivated when it is shipped.

2. To check whether the unit is set in the ALARM ON mode, make sure that the security indicator blinks when the removable face plate is removed.

Display	Security Indicator	Warning Alarm	Horn Alert	Panel Removal Alarm
	Blinks	ON	ON	ON
↑↓ (Press and hold SEL for more than 4 seconds.)				
	OFF	OFF	OFF	OFF

Caution:

1. Warning Alarm and Horn Alert system may not operate if the exclusive supplied mounting collar is not used. This mounting collar will set off the alarm when the unit is being removed.
If the main unit is not correctly wired and installed, the system may accidentally sound the alarm.
2. When removing or installing the unit, make sure that it is in the ALARM OFF mode.
3. When the Warning Alarm is activated by mistake, or when you want to remove the unit, the Warning Alarm and the security indicator functions can be canceled by the following steps of procedure.
 - Install the removable face plate.
 - Disconnect the power connector.

Panel Removal Alarm

This alarm sounds to warn you not to forget to remove the panel before leaving your car. This function is activated when the security alarm is ON.

Installation

Preparation

- Before installation check the radio operation with antenna and speakers.
- Disconnect the cable from the negative (-) battery terminal (see caution below).

Caution:

For installation to cars with trip or navigational computers, all electronic memory settings previously registered in the computer will be lost when the battery terminal is disconnected. For this type of car, battery could not be disconnected. Therefore, extra care should be taken to prevent short circuiting.

In-dash Installation

Installation Opening

In-dash installation can be done if the car's dashboard has an opening for this unit as shown in Fig.

1. The car's dashboard should have a thickness of 4.5mm - 6mm in order to make the installation of the unit.

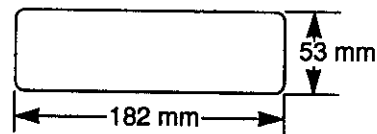

Fig. 1

Installation Precautions

This equipment, if possible, should be installed by a professional installer.

In case of difficulty, please consult your nearest authorized Panasonic Service Center.

1. This system is to be used only in a 12-volt, DC battery system (car) with negative ground.
2. Follow the electrical connection on page 40 carefully. Failure to do so may result in damage to the unit.
3. Connect the power lead after other connections are made.
4. Be sure to connect the YELLOW lead to the positive terminal (+) of the battery or fuse block (BAT) terminal.
5. Insulate all exposed wires to prevent short circuiting.
6. Secure all loose wires after installing the unit.
7. Please carefully read the operating and installation instructions of the respective equipment before connecting it to this unit.

Supplied Hardwares

No.	Item	Diagram	Q'ty
①	Mounting Collar		1
②	Plain Washer (5 mmφ)		2
③	Spring Washer (5 mmφ)		2
④	Hex. Nut (5 mmφ)		2
⑤	Rear Support Strap		1
⑥	Hex. Bolt (5 mmφ x 25 mm)		1
⑦	Toothed Lock Washer (5 mmφ)		1

No.	Item	Diagram	Q'ty
⑧	Mounting Bolt (5 mmφ)		1
⑨	Power Connector		1
⑩	Removable Face Plate Case		1
⑪	Remote Control Unit (Only for CQ-FX65LEN) Remote Control Unit (Only for CQ-FX45LEN)		1
⑫	Trim Plate		1
⑬	Dismounting Plate		1
⑭	Lithium Battery		1

Installation continued

Installation Procedures

1. Secure the Mounting Collar ①.

Insert Mounting Collar ① into the car's dashboard, and bend mounting tabs out with a screwdriver.

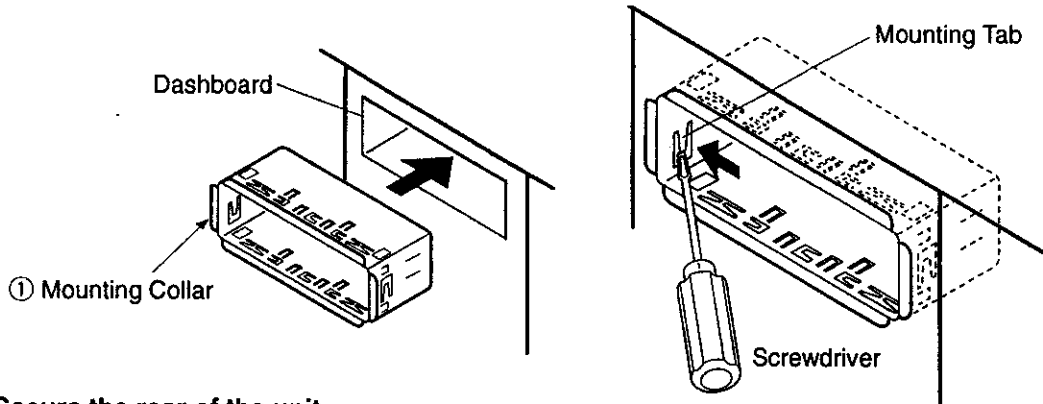

2. Secure the rear of the unit.

- a) Check the electrical connection by referring to this operating instructions.
- b) Connect the Mounting Bolt ⑧, using a suitable wrench.
- c) Insert the unit into Mounting Collar ① and push it in until "click" is heard.

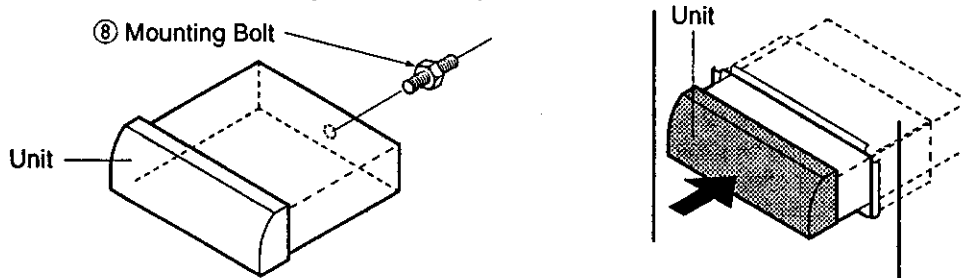

d) Secure the rear of the unit to the car by either of the two recommended methods.

■ Using the Rear Support Strap ⑤

Affix one end of the Rear Support Strap ⑤ to the rear of the unit, and the other end to the Fire Wall of Car, or some other metallic area.

■ Using the Rubber Cushion (Optional)

(If there is an existing Rear Support Bracket on the Fire Wall of Car.)

Cover Mounting Bolt ⑧ on the rear of the unit with Rubber Cushion (Optional), and mount it into the existing Rear Support Bracket.

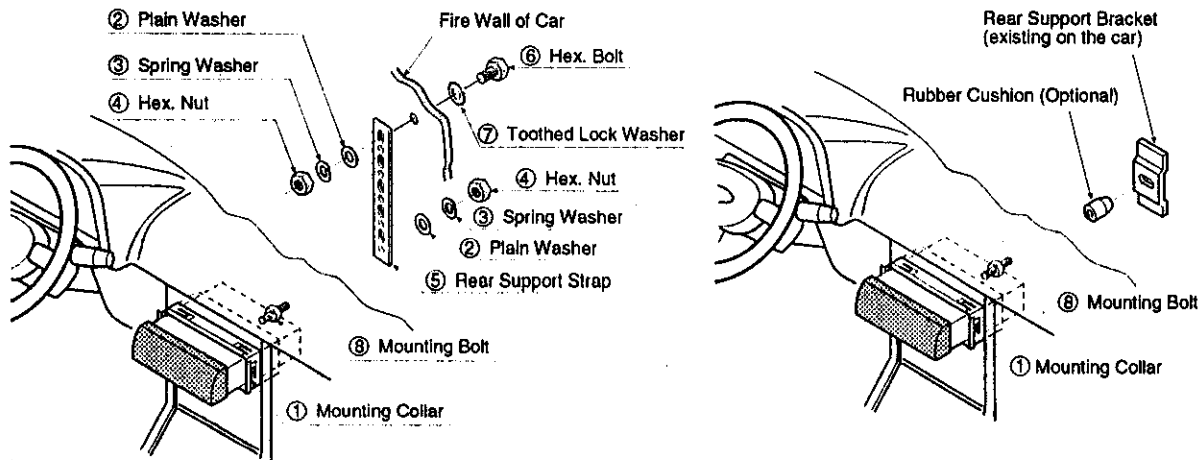

3. a) Plug the Power Connector ⑨.
b) Install the Trim plate ⑫.

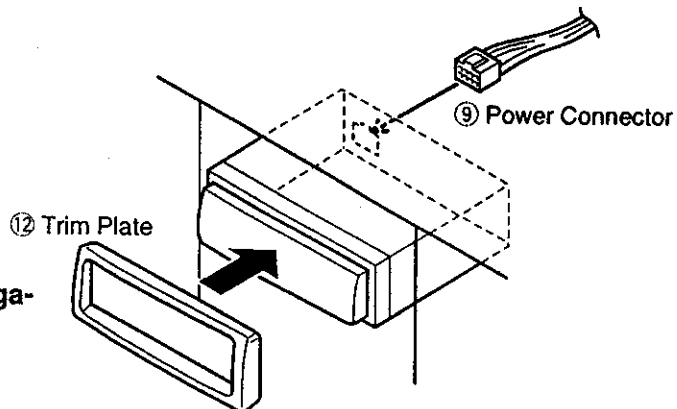

4. After installation reconnect the negative (-) battery terminal.

To Remove the Unit

- a) Remove the trim plate with a screwdriver as shown in the figure.

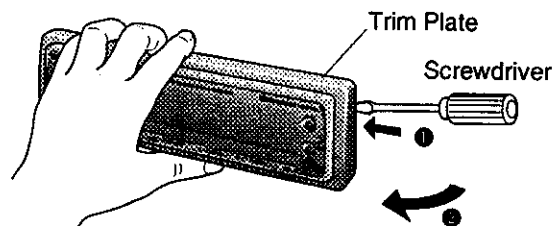

- b) Pull out the unit while pushing the lock lever using Dismounting Plate ⑬.
c) Remove the unit pulling with both hands.

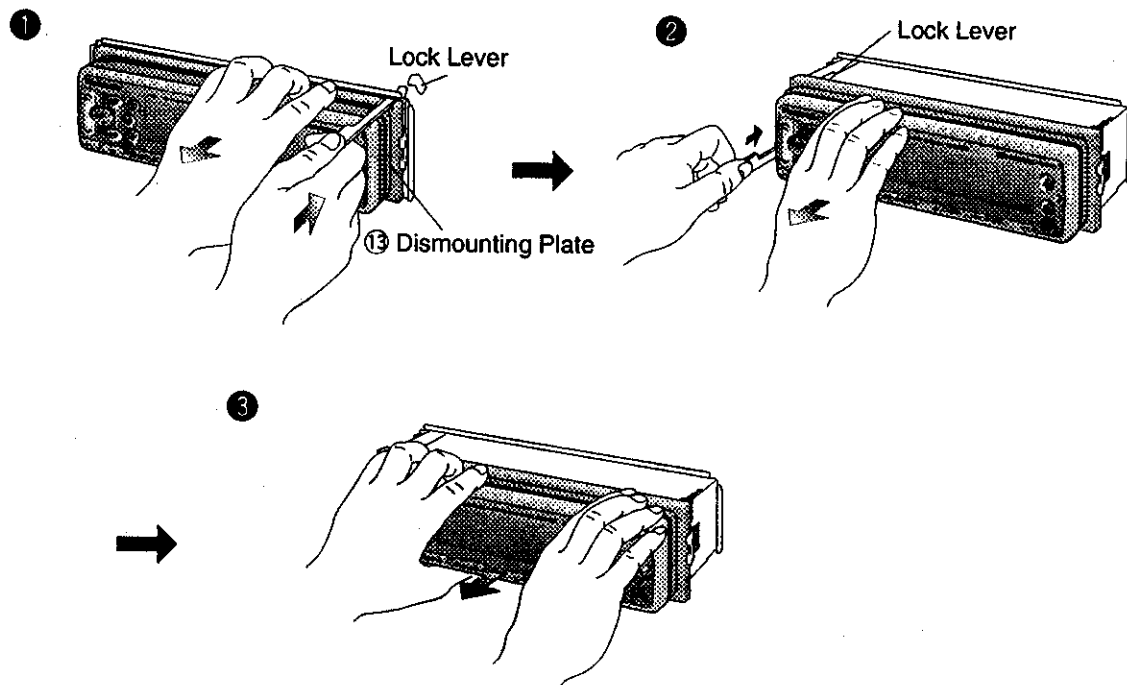

Note: Do not lose the Dismounting Plate. It will be needed to remove the unit from the car's dashboard.

Electrical Connection

Caution:

- Confirm the note on page 4, and make connections to the connectors on car side.
- To prevent damage to the unit, be sure to follow the connection diagram below.
- Remove the covering of the leads about 5 mm long from their end before connecting. (the cords except for ISO connector's cords)
- Do not insert the power connector into the unit until the wiring is completed.
- Be sure to insulate any exposed wires from a possible short-circuit from the car chassis. Bundle all cables and keep cable terminals free from touching any metal parts.

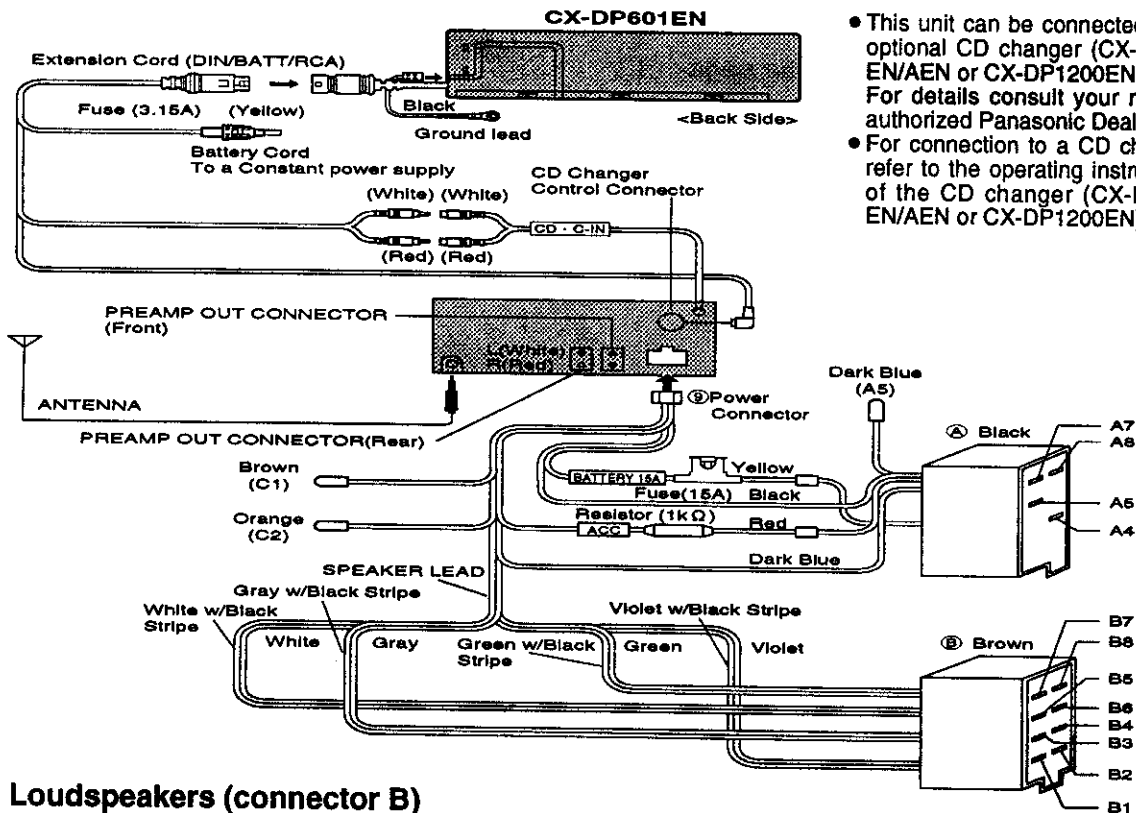

- This unit can be connected to an optional CD changer (CX-DP600 EN/AEN or CX-DP1200EN). For details consult your nearest authorized Panasonic Dealer.
- For connection to a CD changer, refer to the operating instructions of the CD changer (CX-DP600 EN/AEN or CX-DP1200EN).

Loudspeakers (connector B)

	Left +	Left -	Right +	Right -
Front	B5 (White)	B6 (White w/Black Stripe)	B3 (Gray)	B4 (Gray w/Black Stripe)
Rear	B7 (Green)	B8 (Green w/Black Stripe)	B1 (Violet)	B2 (Violet w/Black Stripe)

A4

BATTERY LEAD (To Battery of Car) (Yellow)
Connect to the "BAT" terminal on the fuse block of the car. The power should be supplied continuously to the yellow leads regardless of the on/off position of the ignition key.

A5

MOTOR ANTENNA RELAY CONTROL LEAD (Dark Blue)
(To Motor Antenna) (Max. 500mA)
This lead is not intended for use with switch actuated power antenna.
AMP-RELAY CONTROL POWER LEAD
This lead is for connection to Panasonic power amplifier.

A7

POWER LEAD (Red)
Connect to the "radio" power line of the car or to the "IGN" or "ACC" terminal of the fuse block.

A8

GROUND LEAD (Black)
Connect to a well grounded metallic part of your car.

C1

Horn Alert CONTROL LEAD (Brown)
(To Horn Alert UNIT) (CA-HAL1EN)

C2

TELEPHONE MUTE LEAD (Orange)
(To car telephone mute line)
TELEPHONE MUTE
The telephone mute lead, if connected to the car telephone mute line, will activate the muting circuit and the sound from the speakers cannot be heard while the telephone conversation is in progress.
Note: This telephone mute lead is for connection only to the radio mute line. Be sure to ascertain this because it will not work with other type of output system.

Speaker Connections

CAUTION:

1. Use ungrounded speakers only.
2. The speakers to be used with this unit should be able to handle more than 40W of audio power. If an optional amplifier is used, the speakers should be able to handle the maximum output power of the amplifier. Use of speakers with small input ratings can cause damage to the speakers.
3. The speaker impedance should be 4 - 8 ohms. If the impedance is too large or too small, it affects the output and may cause damage to the speakers or this unit.
4. Do not use 3-wire type speaker system having a common earth lead. Never connect the speaker cord to the body of the car. This unit uses the BTCL circuit, so each speaker should be connected separately using parallel vinyl insulated cords.
5. The speaker cords and the power amplifier unit should be kept away (about 30cm apart) from the antenna and antenna extension cord.
6. Follow the connection diagram below carefully. Failure to do so may cause damage to both unit and speakers.

- Unit will be damaged if speakers (Front, Rear) are not connected properly.

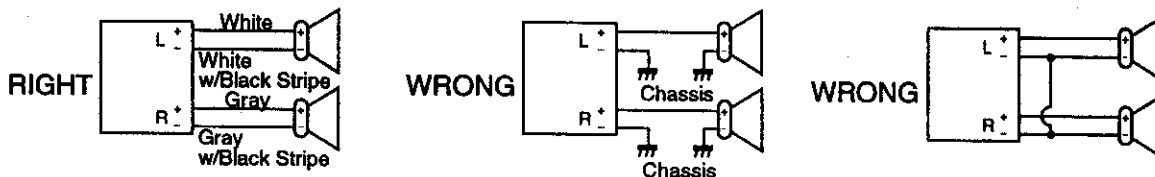

- Do not connect more than one speaker to one set of speaker leads.



Fuse

Be sure to use a fuse of the specified rating (15A) when replacing a blown fuse. Fuses with higher capacity ratings, use of any substitute, or connection without a fuse may result in a fire hazard or damage to the unit. If the replacement fuse fails, consult your nearest authorized Panasonic Service Center.

Maintenance

To clean the exterior of this unit, use a soft cloth to wipe the surface. Do not use benzine, thinner, or any other type of solvents.

Specifications

General

Power Supply	: DC 12V (11V - 16V), Test Voltage 14.4V, Negative Ground
Tone Controls	: Bass; ± 12 dB at 100Hz Treble; ± 12 dB at 10kHz
Current Consumption	: Less than 2.5A (Tape mode, 0.5W 4-Speaker)
Maximum Power Output	: 40W x 4 (at 4 Ω)
Power Output	: 20W x 4 (DIN45 324, at 4 Ω)
Speaker Impedance	: 4 - 8 Ω
Dimensions (Main unit)	: 178(W) x 50(H) x 150(D) mm
Weight (Main unit)	: 1.7 kg

FM Stereo Radio

Frequency Range	: 87.5 - 108MHz
Usable Sensitivity	: 6dB/ μ V(S/N 30dB)
Stereo Separation	: 35 dB(at 1kHz)

MW Radio

Frequency Range	: 531 - 1,602kHz
Usable Sensitivity	: 28dB/ μ V (S/N 20dB)

LW Radio

Frequency Range	: 153 - 279kHz
Usable Sensitivity	: 32dB/ μ V (S/N 20dB)

Cassette Player

Reproduction System	: 4-track, 2-program stereo
Tape Speed	: 4.76cm/sec.
FF/REW Time	: Less than 110 sec. (C-60)
Frequency Response	: 30 - 17,000Hz (Normal) 30 - 18,000Hz (Metal)
Wow and Flutter	: 0.12% (WRMS)
Signal to Noise Ratio	: 52dB (Dolby B NR on; 62dB)

Note:

Specifications and the design are subject to possible modification without notice due to improvements.

Certain audio features of this product manufactured under a license from Desper Products, Inc., Spatializer[®] and the circle-in-square device are trademarks owned by Desper Products, Inc.

Dolby noise reduction manufactured under license from Dolby Laboratories Licensing Corporation. "DOLBY" and the double-D symbol  are trademarks of Dolby Laboratories Licensing Corporation.